

Vacuum

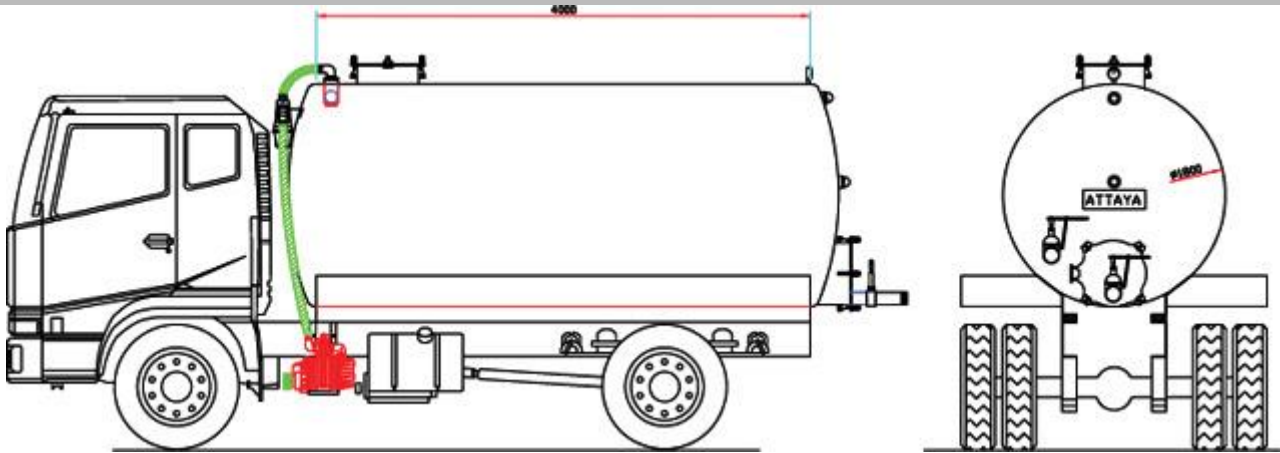

TECHNICAL SPECIFICATIONS

The company is ready to manufacture all types of vacuum tanks, which is using in drainage and heavy rainstorm - available in capacity of 3 m³ : 15 m³ mounted on truck chassis and 30 m³ mounted on trailers.

<p>Tank body :</p>	<p>Spherical shape 6 mm. thickness equipped with internal baffles against water movement during transportation. Tank has dish-end thickness 8 mm. and equipped with the following: Locked manhole for maintenance purpose inside tank in addition rear gate for residual discharge. No.2 high-hardened glass indicator for showing water level. No.2 gate valves made from brass anti rusting. Pressure gauge in order to show tank pressure inside.</p>
<p>Vacuum pump:</p>	<p>Available from 3000 L/M up to 10000 L/M according to the customer request and tank capacity, the pump could be belts or hydraulic operating both through the truck P.T.O. hydraulic driven are optional.</p>
<p>Isolation & paint:</p>	<p>Internal coating with anti rust and chemicals Painting - meantime outer face is coated with primer Coating before color.</p>